

D2PR

Dual Multi-Spring Cartridge

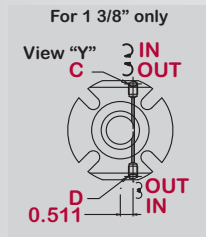
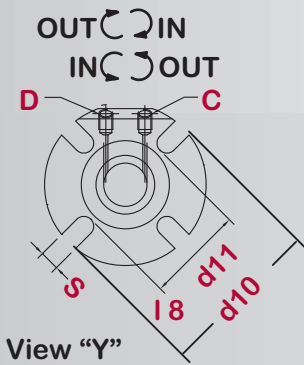
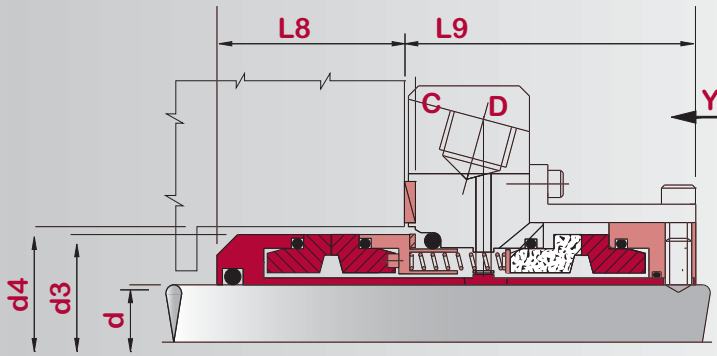

Connection	Size	Rotation	
		CW	CCW
C	3/8 NPT	IN	OUT
D	3/8 NPT	OUT	IN

d	d3	d4	d10	d11	L8	L9	S
1.000	1.594	1.625	4.000	2.224	1.129	2.047	0.551
1.125	1.708	1.750	4.125	2.421	1.129	2.047	0.551
1.250	1.865	2.000	4.250	2.500	1.129	2.047	0.551
1.375	1.950	2.000	4.250	2.696	1.129	2.047	0.551
1.500	2.172	2.250	5.000	2.815	1.129	2.047	0.551
1.625	2.283	2.375	4.500	2.972	1.129	2.047	0.551
1.750	2.401	2.500	5.000	3.062	1.129	2.047	0.551
1.875	2.537	2.625	5.250	3.188	1.129	2.047	0.551
2.000	2.670	2.750	5.500	3.307	1.129	2.188	0.551
2.125	2.795	2.875	5.750	3.503	1.129	2.188	0.709
2.250	2.913	3.000	6.500	3.622	1.129	2.188	0.709
2.375	3.037	3.125	6.500	3.818	1.129	2.188	0.709
2.500	3.288	3.375	7.000	3.976	1.488	2.720	0.709
2.625	3.410	3.500	7.000	4.055	1.488	2.720	0.709
2.750	3.617	3.625	7.000	4.370	1.488	2.720	0.709
3.000	3.795	4.000	7.480	5.079	1.488	2.720	0.709



Features and Benefits:

- Pumping ring standard
- For critical, toxic and non-lubricating fluids
- Stationary multiple spring cartridge design
- Easy cartridge installation
- Interchangeable components with S1 single cartridge
- ANSI pump-compatible
- Non-clogging in stuffing box
- Springs protected from the product
- Compensates for pressure reversals
- Inboard silicon carbide vs silicon carbide faces combination is standard
- User friendly setting clips
- The industry's only double cartridge seal with three identical monolithic silicon carbide faces

Standard Materials of Construction:

- **Faces:**
 - INBOARD Silicon Carbide/Silicon Carbide
 - OUTBOARD Carbon/Silicon Carbide
 - Tungsten Carbide and Antimony Carbon available
- **Elastomers:**
 - Viton*, Buna, PTFE, Neoprene, EPDM, Kalrez*, FEP, AFLAS*, Chemraz*
- **Metallurgy:**
 - 316 SS, Alloy 20, Hast B+ C*

Operating Limits:

- Pressure: Up to 300 PSI/20 Bar
- Temperature: From -40° to 500° Fahrenheit* -40° to 260° Celsius*
- Call factory for specific API plans and Barrier flushing pressures

Apex
sealing,inc.

Apex Sealing Inc.
164 B Yankee Park Rd.
Fairfax, VT 05454
888.730.2739
apexsealing.com